

### Product Summary

V <sub>(BR)DSS</sub>	R <sub>DS(on)TYP</sub>	I <sub>D</sub>
-40V	5.3mΩ@-10V	-100A
	7.4mΩ@-4.5V	

### Feature

- Trench Technology Power MOSFET
- Low R<sub>DS(ON)</sub>
- Low Gate Charge
- Low Gate Resistance
- 100% UIS Tested

### Application

- Power Switching Application
- DC/DC Converter

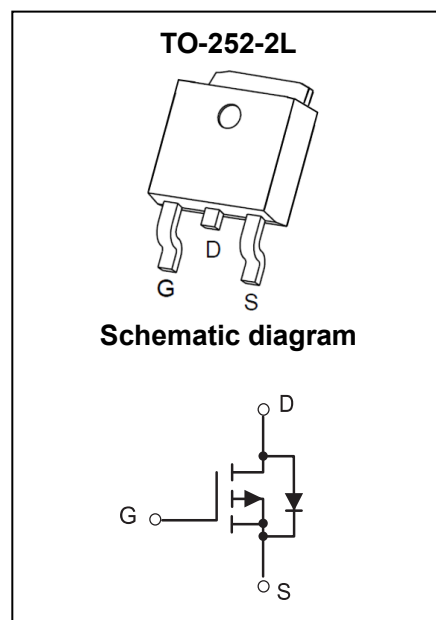

### Package Marking and Ordering Information

Part Number	Package	Marking	Packing	Reel Size	Tape Width	Qty
GPM055P04LTF	TO-252-2L	M055P04L	Reel & Tape	330mm	16mm	2500pcs

### ABSOLUTE MAXIMUM RATINGS (T<sub>A</sub> = 25°C unless otherwise noted)

Parameter	Symbol	Value	Unit	
Drain - Source Voltage	V <sub>DS</sub>	-40	V	
Gate - Source Voltage	V <sub>GS</sub>	±20	V	
Continuous Drain Current <sup>1</sup>	T <sub>C</sub> = 25°C	I <sub>D</sub>	-100	A
	T <sub>C</sub> = 100°C	I <sub>D</sub>	-65	A
Pulsed Drain Current <sup>2</sup>	I <sub>DM</sub>	-400	A	
Single Pulsed Avalanche Current <sup>3</sup>	I <sub>AS</sub>	-42	A	
Single Pulsed Avalanche Energy <sup>3</sup>	E <sub>AS</sub>	411	mJ	
Power Dissipation <sup>5</sup>	T <sub>C</sub> = 25°C	P <sub>D</sub>	96	W
Thermal Resistance from Junction to Ambient <sup>6</sup>	R <sub>θJA</sub>	50	°C/W	
Thermal Resistance from Junction to Case	R <sub>θJC</sub>	1.3	°C/W	
Junction Temperature	T <sub>J</sub>	150	°C	
Storage Temperature	T <sub>STG</sub>	-55~ +150	°C	

## MOSFET ELECTRICAL CHARACTERISTICS ( $T_A = 25^\circ\text{C}$ unless otherwise noted)

Parameter	Symbol	Test Condition	Min	Type	Max	Unit
<b>Off Characteristics</b>						
Drain - Source Breakdown Voltage	$V_{(BR)DSS}$	$V_{GS} = 0V, I_D = -250\mu A$	-40			V
Zero Gate Voltage Drain Current	$I_{DSS}$	$V_{DS} = -40V, V_{GS} = 0V$			-1	$\mu A$
Gate - Body Leakage Current	$I_{GSS}$	$V_{GS} = \pm 20V, V_{DS} = 0V$			$\pm 100$	nA
<b>On Characteristics<sup>4</sup></b>						
Gate Threshold Voltage	$V_{GS(th)}$	$V_{DS} = V_{GS}, I_D = -250\mu A$	-1	-1.5	-3	V
Drain-Source On-Resistance	$R_{DS(on)}$	$V_{GS} = -10V, I_D = -20A$		5.3	7.5	m $\Omega$
		$V_{GS} = -4.5V, I_D = -10A$		7.4	9.5	
<b>Dynamic Characteristics</b>						
Input Capacitance	$C_{iss}$	$V_{DS} = -20V, V_{GS} = 0V, f = 1MHz$		4693		pF
Output Capacitance	$C_{oss}$			503		
Reverse Transfer Capacitance	$C_{rss}$			445		
Gate Resistance	$R_g$	$V_{DS} = 0V, V_{GS} = 0V, f = 1MHz$		5		$\Omega$
<b>Switching Characteristics</b>						
Total Gate Charge	$Q_g$	$V_{DS} = -40V, V_{GS} = -10V, I_D = -20A$		96.1		nC
Gate-Source Charge	$Q_{gs}$			11.6		
Gate-Drain Charge	$Q_{gd}$			21		
Turn-On Delay Time	$t_{d(on)}$	$V_{DD} = -20V, V_{GS} = -10V, I_D = -19A, R_G = 3\Omega$		15		ns
Turn-On Rise Time	$t_r$			5		
Turn-Off Delay Time	$t_{d(off)}$			180		
Turn-Off Fall Time	$t_f$			90		
<b>Source - Drain Diode Characteristics</b>						
Diode Forward Voltage <sup>4</sup>	$V_{SD}$	$V_{GS} = 0V, I_S = -10A$			-1.2	V

Notes :

- 1.The maximum current rating is limited by package.And device mounted on a large heatsink
- 2.Pulse Test : Pulse Width  $\leq 10\mu s$ , duty cycle  $\leq 1\%$ .
- 3.EAS condition:  $V_{DD} = -20V, V_{GS} = -10V, L = 0.5mH, R_G = 25\Omega$  Starting  $T_J = 25^\circ\text{C}$ .
- 4.Pulse Test : Pulse Width  $\leq 300\mu s$ , duty cycle  $\leq 2\%$ .
- 5.The power dissipation  $P_D$  is limited by  $T_{J(MAX)} = 150^\circ\text{C}$ .And device mounted on a large heatsink
- 6.Device mounted on  $1in^2$  FR-4 board with 2oz. Copper, in a still air environment with  $T_A = 25^\circ\text{C}$ .

**Typical Characteristics**

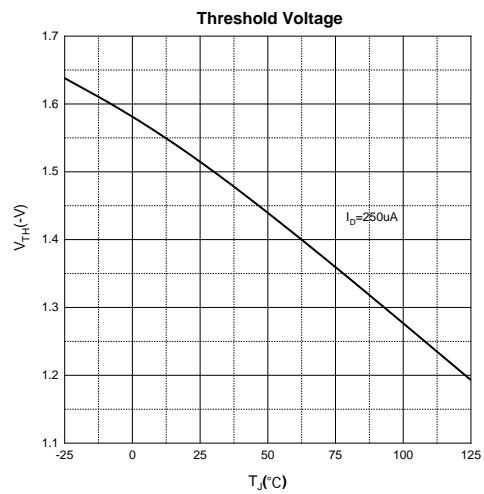
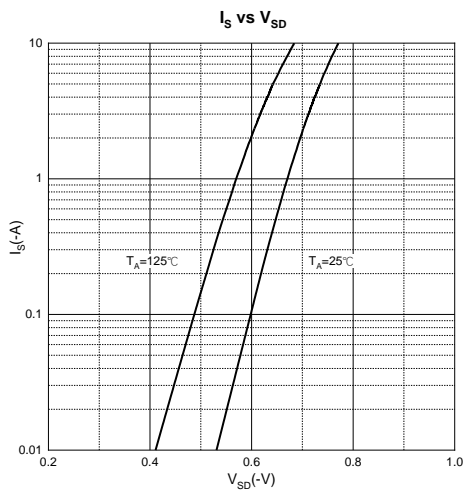
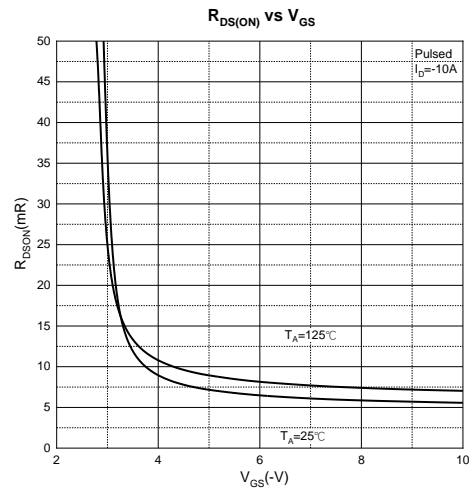
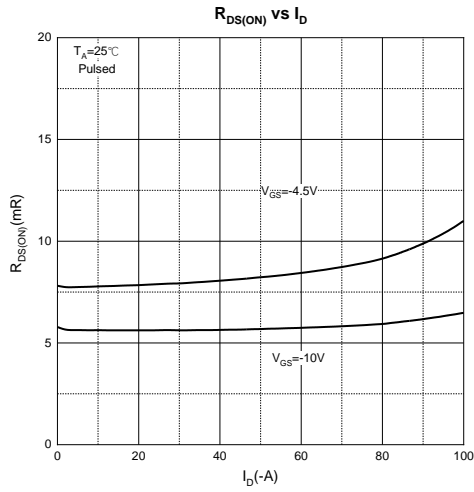
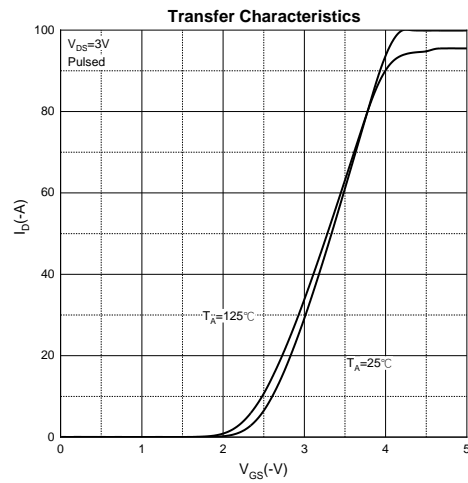
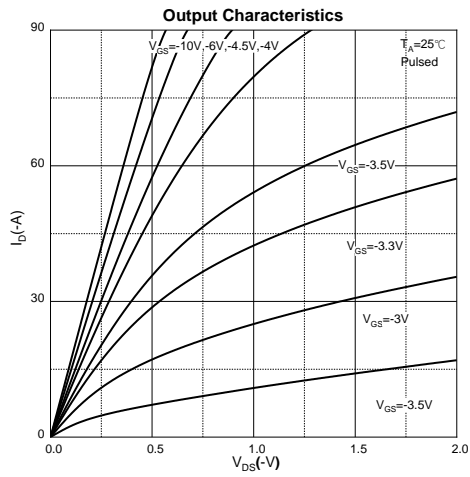

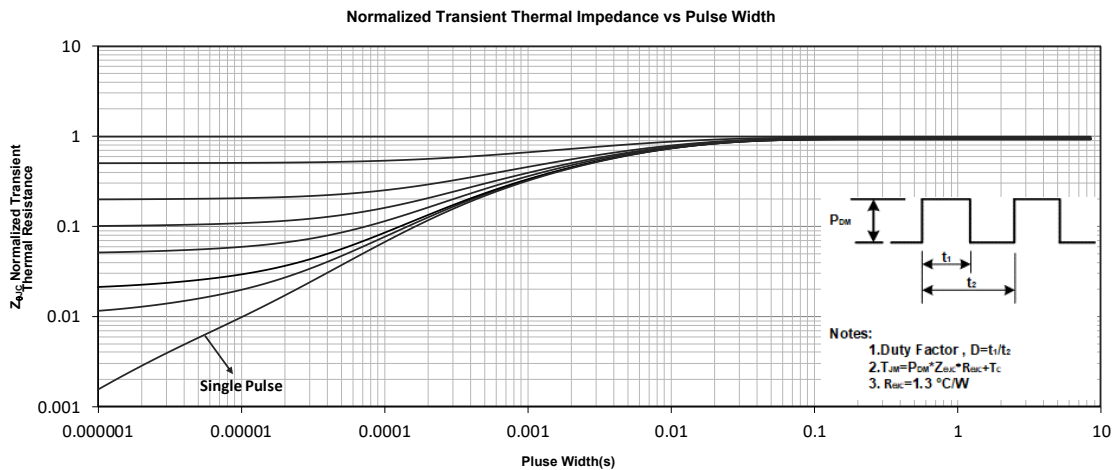
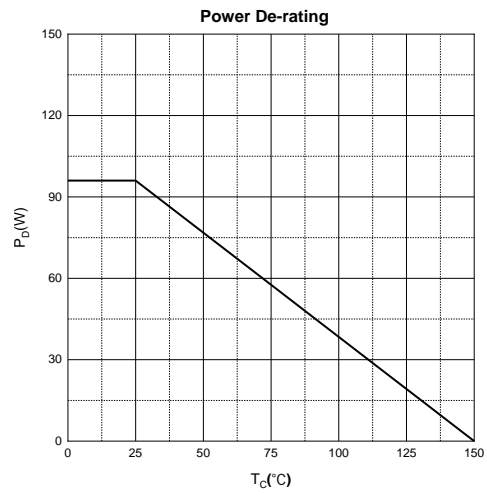
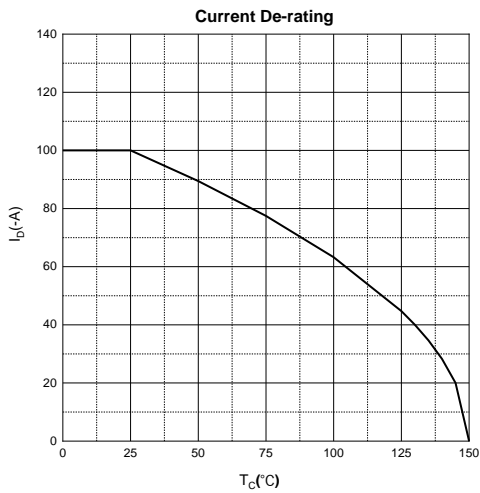
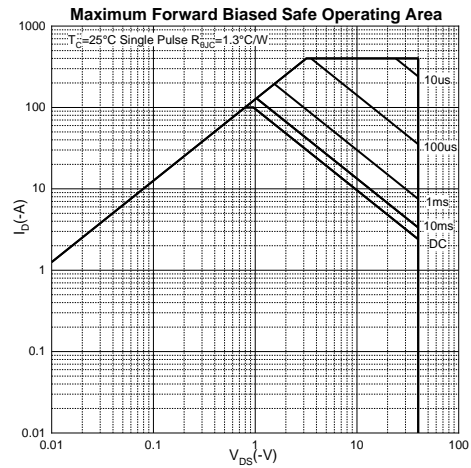
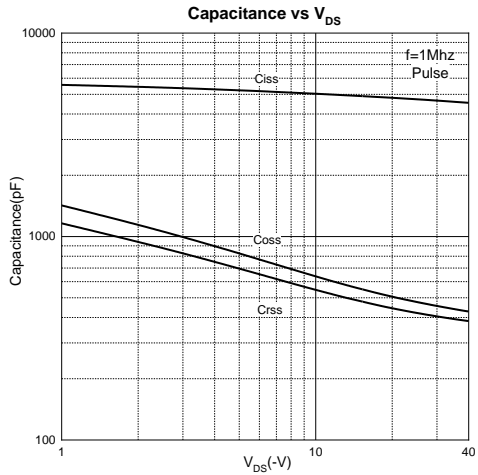

**Gate Charge Test Circuit & Waveform**

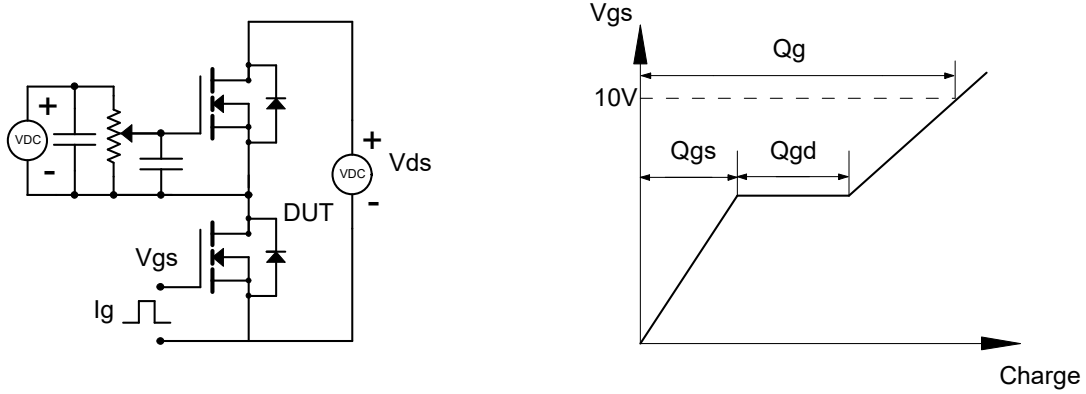

**Resistive Switching Test Circuit & Waveform**

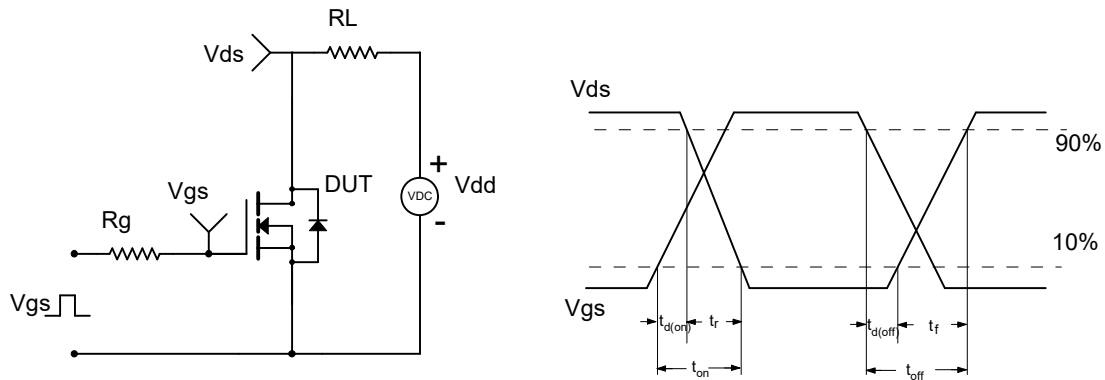

**Unclamped Inductive Switching (UIS) Test Circuit & Waveforms**

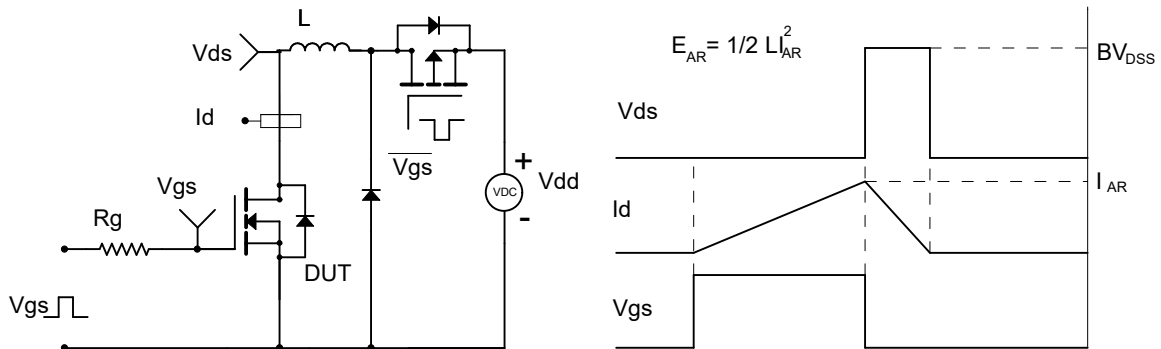

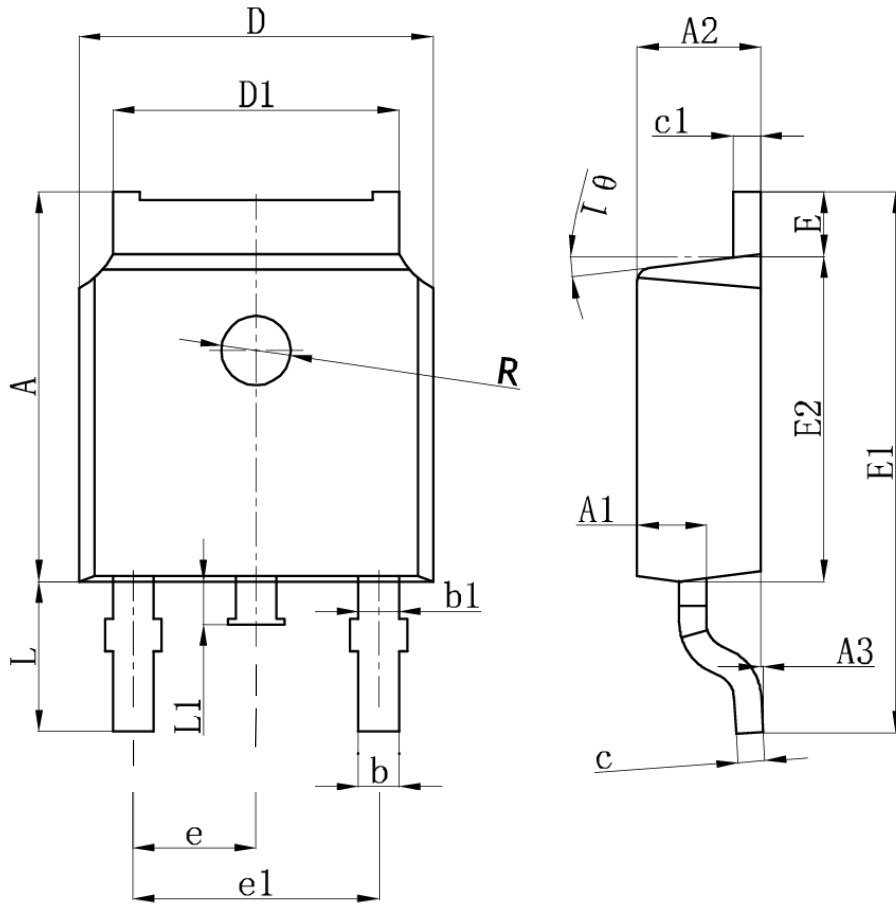
**TO-252-2L Package Information**

Symbol	Dimensions In Millimeters		Dimensions In Inches	
	Min.	Max.	Min.	Max.
A	6.850	7.250	0.269	0.285
A1	0.960	1.060	0.038	0.042
A2	2.200	2.400	0.087	0.094
A3	0.000	0.15	0.000	0.006
b	0.760REF		0.030REF	
b1	1.000REF		0.039REF	
c	0.508REF		0.020REF	
c1	0.508REF		0.020REF	
D	6.250	6.850	0.246	0.270
D1	5.050	5.650	0.199	0.222
E	0.850	1.200	0.033	0.047
E1	9.700	10.400	0.382	0.409
E2	5.800	6.400	0.228	0.252
e	2.286BSC		0.090BSC	
e1	4.572REF		0.180REF	
L	2.650	2.950	0.104	0.116
L1	0.600	1.000	0.024	0.039
$\theta$	7°REF		7°REF	
R	1.300REF		0.051REF	

**Attention:**

- GreenPower Electronics reserves the right to improve product design function and reliability without notice.
- Any and all semiconductor products have certain probability to fail or malfunction, which may result in personal injury, death or property damage. Customer are solely responsible for providing adequate safe measures when design their systems.
- GreenPower Electronics products belong to consumer electronics or other civilian electronic products.